

Early Childhood RESOURCES

Mt. Laurel, NJ 08054 USA
www.ecr4kids.com

Book Display with Storage - 3 Compartment - Model# ELR-0728

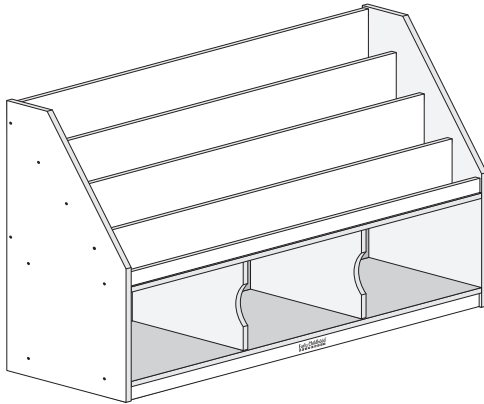

⚠ WARNING:

Adult Assembly Required.

Two adults recommended.

- Contains small parts, sharp points and edges.
- Do not stand, sit, kneel, climb, lean or pull on unit for support.
- Never leave children unattended.
- Do not place unit near high heat or moisture.
- Adult supervision recommended.

TOOLS INCLUDED

Hex Tool (1)





TOOLS NEEDED

Phillips Screwdriver

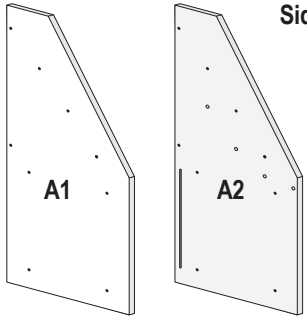
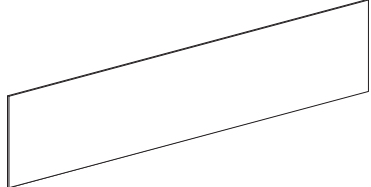
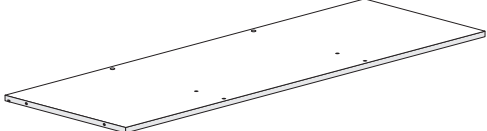
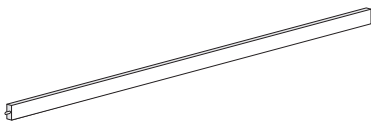
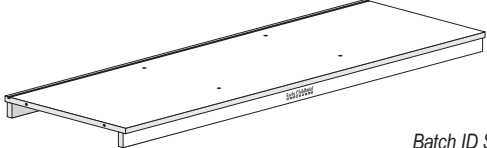
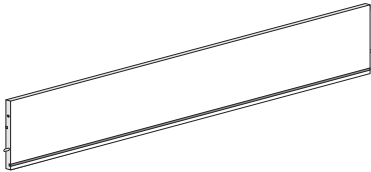
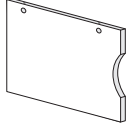
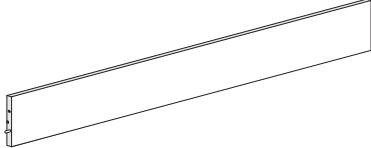
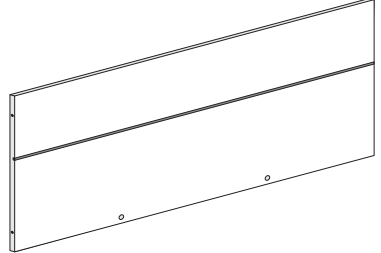
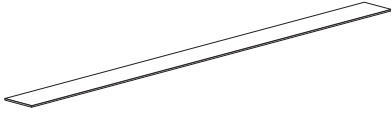
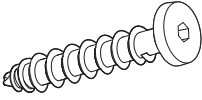
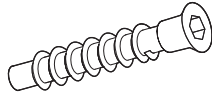

Parts List

BEFORE ASSEMBLING, MAKE SURE YOU HAVE ALL THE PARTS

A  <p>Left & Right Side Panels (1/1)</p>	F  <p>Lower Back Panel (1)</p>
B  <p>Top Panel (1)</p>	G  <p>Front Crossbar (1)</p>
C  <p>Bottom Shelf (1)</p>	H  <p>Rear Dividers (2)</p>
D  <p>Lower Dividers (2)</p> <p><i>Batch ID Sticker located on underside</i></p>	I  <p>Front Divider (1)</p>
E  <p>Upper Back Panel (1)</p>	J  <p>Shelves (3)</p>
K  <p>Decorative Hex Screws (22)</p> <p><i>Use the Hex Tool.</i></p>	L  <p>Flat Head Hex Screws (4)</p> <p><i>Use the Hex Tool.</i></p>
M  <p>Cam Posts & Cam Locks (6/6)</p> <p>M1 M2</p> <p><i>Use a Phillips Screwdriver.</i></p>	

1 Install Lower Dividers

Install the **Lower Dividers (D)** onto the **Bottom Shelf (C)** with four **Decorative Hex Screws (K)** using the Hex Tool.

Note: The groove on the **Bottom Shelf** is toward the ground.

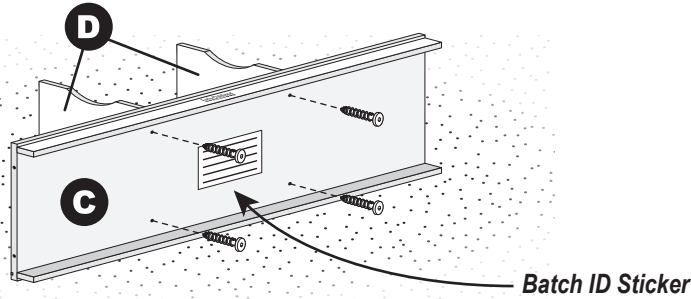

2 Install Front Crossbar & Front Divider

Install the **Front Crossbar (G)** and **Front Divider (I)** onto the **Top Panel (B)** with four **Flat Head Hex Screws (L)** using the Hex Tool.

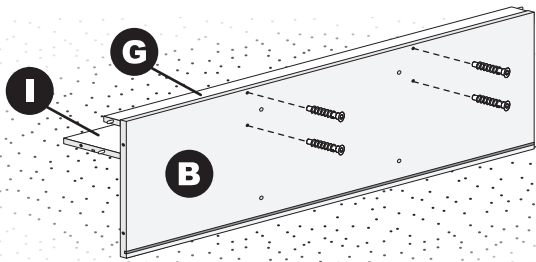

Install four **Cam Posts (M1)** into the threaded plastic inserts on the underside of **Top Panel (B)** with a Phillips screwdriver.

Reminder: Do not overtighten, as the plastic threads can be stripped.

3 Connect Top Panel to Lower Dividers

Place two **Cam Locks (M2)** into the recessed holes on each **Lower Divider (D)** with the arrow facing the closest edge.

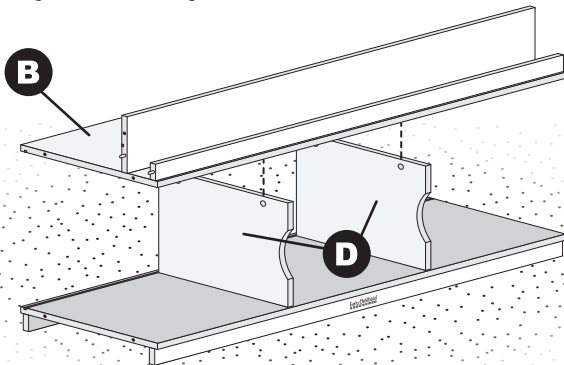

Insert the **Top Panel (B)** Cam Posts into the holes on the top edge of the **Lower Dividers (D)**. Turn the Cam Locks clockwise with a Phillips screwdriver to lock the **Lower Dividers (D)** onto the posts.

4 Insert the Lower Back Panel

Slide the **Lower Back Panel (F)** into the grooves on the underside of **Top Panel (B)** and top side of the **Bottom Shelf (C)** as shown, center the panel so it will seat into the grooves on the inside of the Side Panels.

Tip: If the Back Panel does not slide in easily, wiggle the panel while pushing into place.

Install two **Cam Posts (M1)** into the threaded plastic inserts on the top side of **Top Panel (B)** with a Phillips screwdriver.

Reminder: Do not overtighten, as the plastic threads can be stripped.

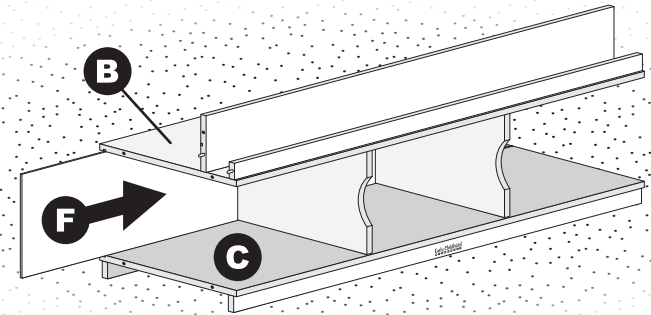

5 Connect the Upper Back Panel

Place two **Cam Locks (M2)** into the recessed holes on the **Upper Back Panel (E)** with the arrow facing the closest edge.

Insert the **Upper Back Panel (E)** onto the **Cam Posts (M1)** on the top side of **Top Panel (B)**. Turn the Cam Locks clockwise with a Phillips screwdriver to lock the **Upper Back Panel (E)** onto the posts.

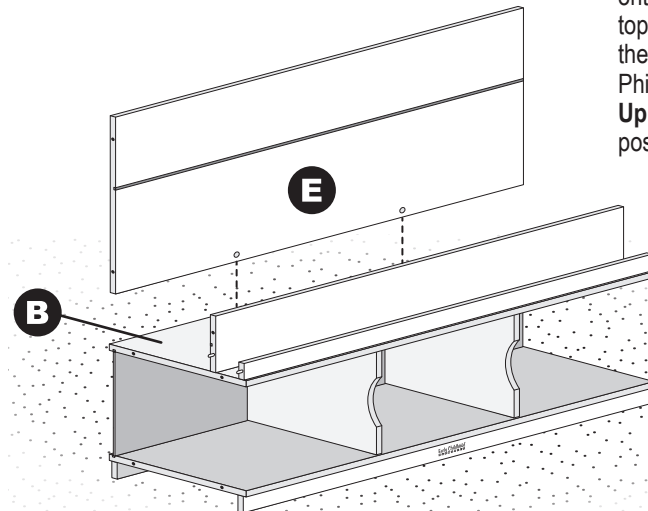

See Next Page

6 Install the Left Side Panel

Install the **Left Side Panel (A1)** onto the **Top Panel (B)**, **Bottom Shelf (C)**, **Upper Back Panel (E)** and **Front Divider (I)** with seven **Decorative Hex Screws (K)** using the Hex Tool.

Reminder: Make sure the pre-installed wood dowels on the ends of the **Front Divider** and **Crossbar** enter the corresponding holes on the inside of the **Side Panels** before final tightening.

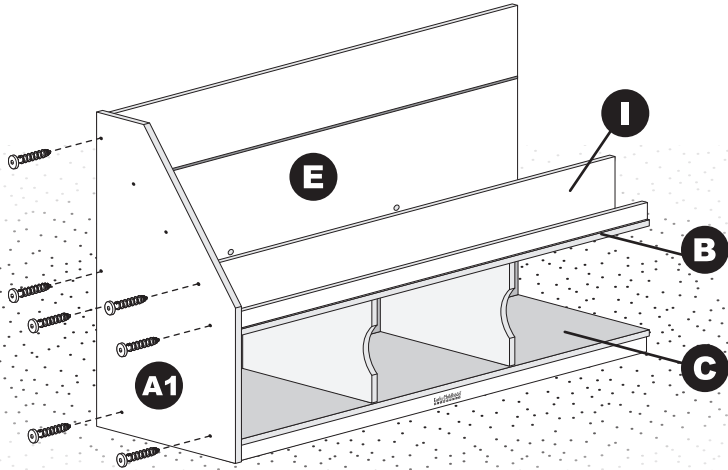

8 Install the Shelves

Slide the **Shelves (J)** into the grooves on the sides of **Upper Back Panel (E)** and **Front/Rear Dividers (G/H)** as shown, until seated against the inside of **Left Side Panel (A1)**.

Tip: If the **Shelves** do not slide in easily, wiggle them while pushing into place.

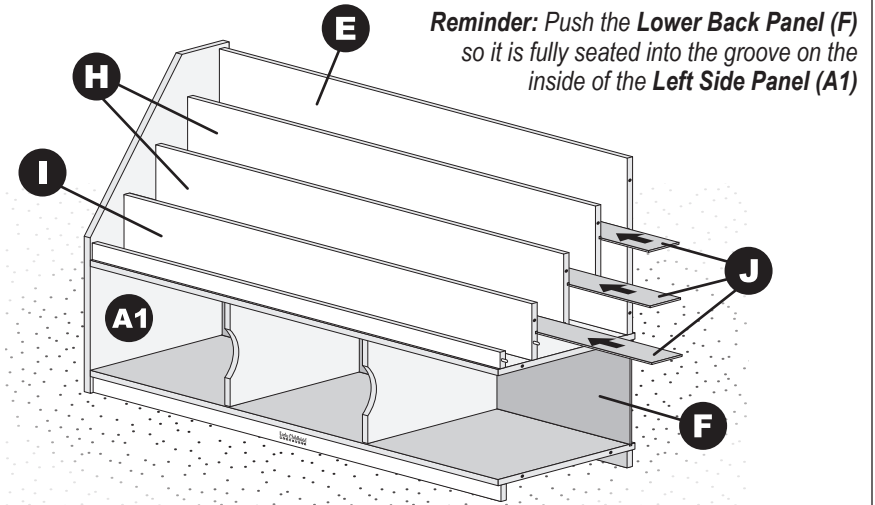

7 Install the Rear Dividers

Install the **Rear Dividers (H)** onto the **Left Side Panel (A1)** with two **Decorative Hex Screws (K)** using the Hex Tool, with the pre-installed wood dowels on the ends entering their corresponding holes.

Reminder: Make sure the grooves on the **Rear Dividers (H)** align with those on the **Upper Back Panel (E)** and **Front Divider (I)**.

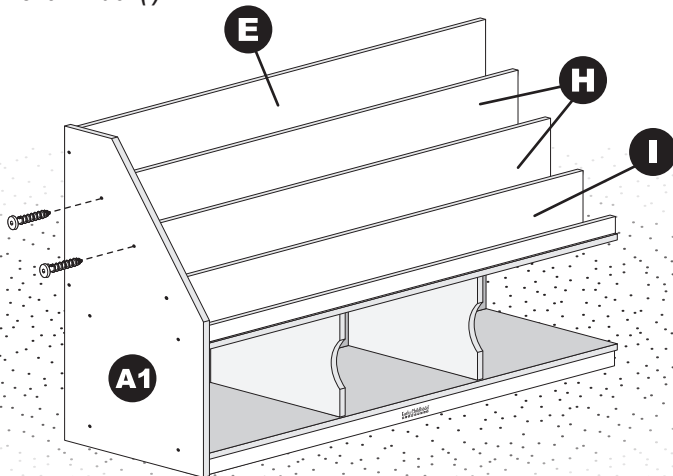

9 Install the Right Side Panel

Install the **Right Side Panel (A2)** onto the **Top Panel (B)**, **Bottom Shelf (C)**, **Upper Back Panel (E)** and **Front/Rear Dividers (G/H)** with nine **Decorative Hex Screws (K)** using the Hex Tool.

Reminder: Make sure the pre-installed wood dowels on the ends of the **Front/Rear Dividers** and **Crossbar** enter the corresponding holes on the inside of the **Side Panel** before final tightening.

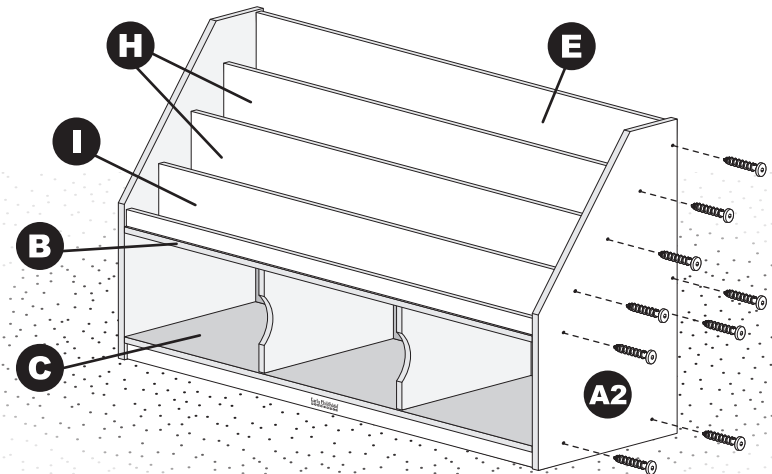

See Next Page



We appreciate your purchase of the Book Display with Storage - 3 Compartment. Early Childhood Resources has made every effort to supply a quality product, that with proper use and care, will bring you many years of trouble free use!

If you experience any difficulties with this product, please email us at customerservice@ecr4kids.com or call toll-free at (888) 227-9028 (Monday - Friday, 7:00am - 4:00pm Pacific Standard Time)

Please do not return to place of purchase as Early Childhood Resources will replace defective part(s) and/or product.



"Early Childhood Resources® guarantees the quality of all of our products. You can trust the quality and safety of our furniture and materials, along with the peace of mind that our products are made to last. If for any reason, you are not satisfied with the quality and workmanship of our products, we will replace the item or refund the sale."

Care and Cleaning

Clean unit with a damp cloth or sponge using warm water and mild soap. Wipe dry.

Do not place near heat, moisture or vaporizer which may cause panels to warp and peel.

Check for loose or worn parts periodically and tighten or replace as necessary.

**Record the manufacture date here.
Information is located on the Batch ID
sticker and on the shipping carton.
Save this sheet in an accessible place.**

Model Number: ELR-0728

Factory Code: D

Manufacture Date: _____

Batch ID Number: _____
(Located on Part C)